

# Internal Bobbin Probe D-B-ID Series

## Description

This probe is designed for the internal tube inspection of non-ferromagnetic tubing. The probe can be operated in differential mode for detection of local defects as well as in absolute mode for detection of gradual wall thinning. The delrine or polyurethane centerings are adjustable to ensure a safe centering in the inspected tube and a reduced wobble signal.

## Technical Data

Freq. Range	: 1 kHz - 30 kHz (red marking) 10 kHz - 200 kHz (yellow marking) 100 kHz - 400 kHz (blue marking) 300 kHz - 1 MHz (green marking)
Coil Assem.	: Bridge mode (differential) (For absolute use reference mode)
Centering	: - none (type D-B-ID) - adjustable polyurethane plugs (type D-B-ID.CPU) - adjustable delrine springs (type D-B-ID.CDE)
Diameter	: 6 mm - 80 mm
Cable Length	: standard 15 m (different cable length upon customer request)
PE-hose	: standard 8.0mm
Connector	: Amphenol 4-pins (different connector upon customer request)

## Accessories

\* probe certificate

## Order Information

\* Necessary specifications:

- centering type
- frequency range
- probe diameter in mm
- cable length
- hose diameter in mm
- connector type

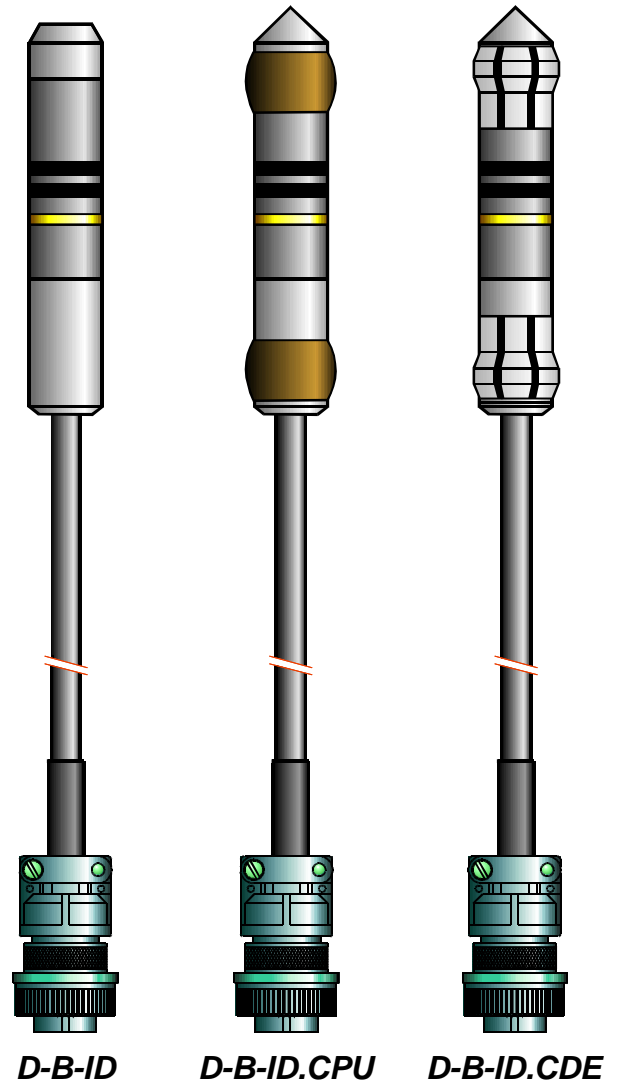

# Internal Flexible Bobbin Probe D-B-ID.X Series

## Description

This probe is designed for the internal inspection of U-bends in non-ferromagnetic tubes. The probe can be operated in differential mode for detection of local defects as well as in absolute mode for detection of gradual wall thinning. The delrine or polyurethane centerings and balls ensure a safe centering in the inspected tube

## Technical Data

Freq. Range	: 1 kHz - 30 kHz (red marking) 10 kHz - 200 kHz (yellow marking) 100 kHz - 400 kHz (blue marking) 300 kHz - 1 MHz (green marking)
Coil Assem.	: bridge mode (differential) (For absolute use reference mode)
Centering	: - delrine rings - polyurethane plugs
Diameter	: 14 mm - 50 mm
Cable Length	: standard 15 m (different cable length upon customer request)
PE-hose	: standard 8.0mm
Connector	: Amphenol 4-pins (different connector upon customer request)

## Accessories

\* probe certificate

## Order Information

\* Necessary specifications:

- centering type
- probe diameter in mm
- cable length
- hose diameter in mm
- connector type

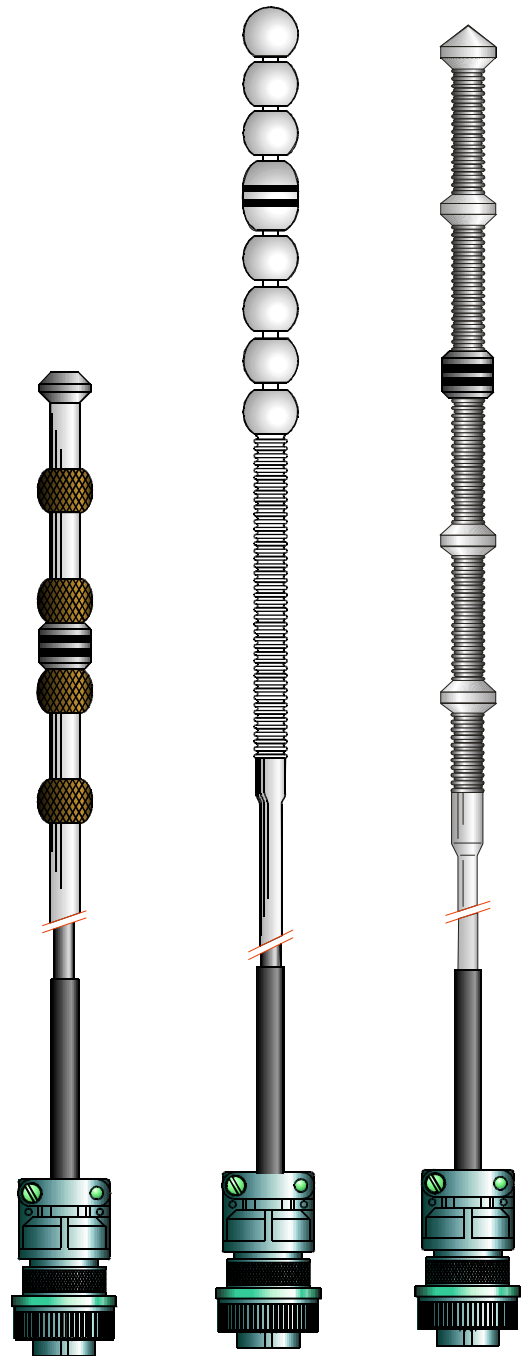

**D-B-ID.XCPU**

**D-B-ID.XCDE**

**D-B-ID.XC-Ball**

# Remote Field Eddy Current Probe For Ferromagnetic Tubes DA-T-ID Series

## Description

This probe is designed for the internal tube inspection of ferro-magnetic tubes. The probe can be operated in differential mode for detection of local defects as well as in absolute mode for detection of gradual wall thinning.

Single and a dual exciter coil versions are available.

The probes can only be operated in combination with the eddyMax-CMEC extension

## Technical Data

Centering	: - none - adjustable polyurethane plugs
Diameter	: 10 mm - 80 mm
Cable Length	: standard 15 m (different cable length upon customer request)
PE-hose	: standard 8.0mm
Connector	: Amphenol 6-pins (different connector upon customer request)

## Accessories

\* probe certificate

## Order Information

\* Necessary specifications:

- dual or single exciter coil type
- probe diameter in mm
- cable length
- hose diameter in mm
- connector type

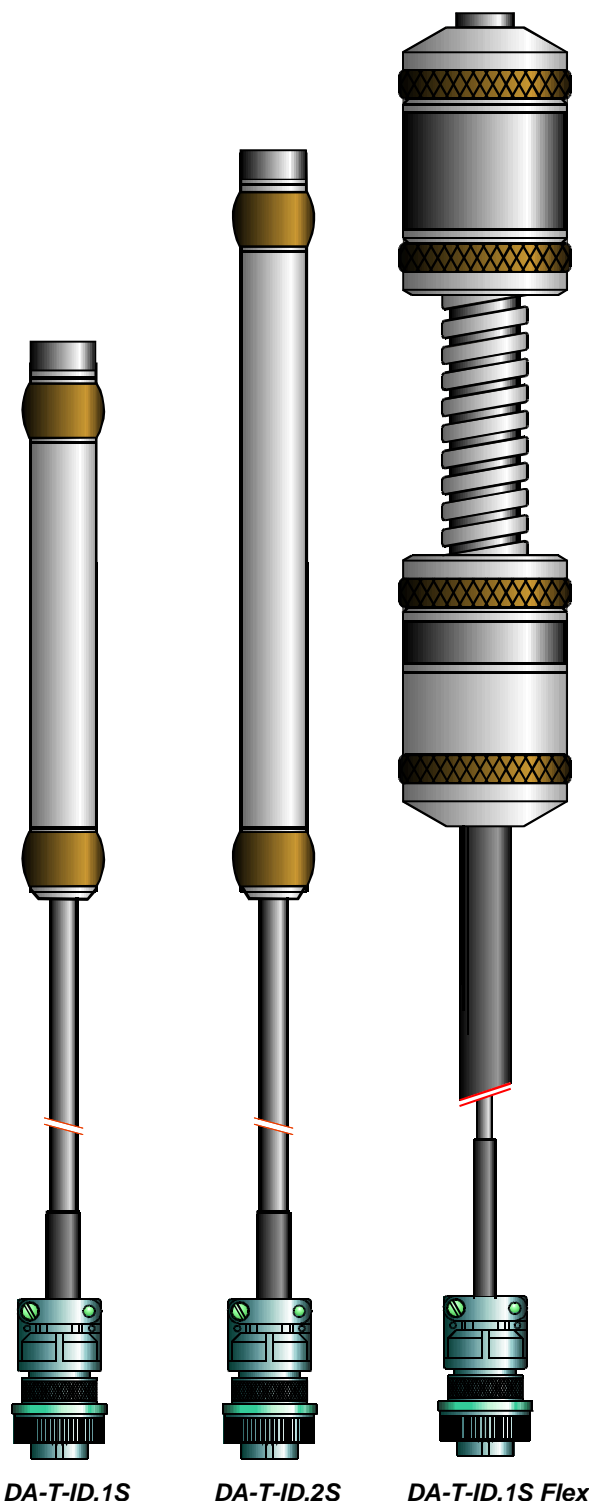

# Internal Bobbin Probe D-B-IDMA Series

## Description

This probe is designed for the internal tube inspection of ferromagnetic tubing. It contains a DC-magnetising coil for material magnetisation and the eddy current coil system. The probe is operated in differential mode for detection of local defects. The probe body is protected against wear by chromium coating.

## Technical Data

Freq. Range	: 10 kHz - 200 kHz
Coil Assem.	: bridge mode (differential)
Centering	: - none
Diameter	: 9 mm - 30 mm
Cable Length	: standard 15 m (different cable length upon customer request)
PE-hose	: standard 10.0mm
Connector	: Amphenol 4-pins - ec-system 2x single plug - magnetisation (different connector upon customer request)

## Accessories

\* probe certificate

## Order Information

\* Necessary specifications:

- probe diameter in mm
- cable length
- hose diameter in mm
- connector type

